

Technical data

membrane tube diffuser MAGNUM T[®]

04 2008



- | | |
|---------------------|------------------------|
| 1. support pipe PP | 4. flooded compartment |
| 2. membrane | 5. internal thread |
| 3. air distribution | 1" stainless steel |

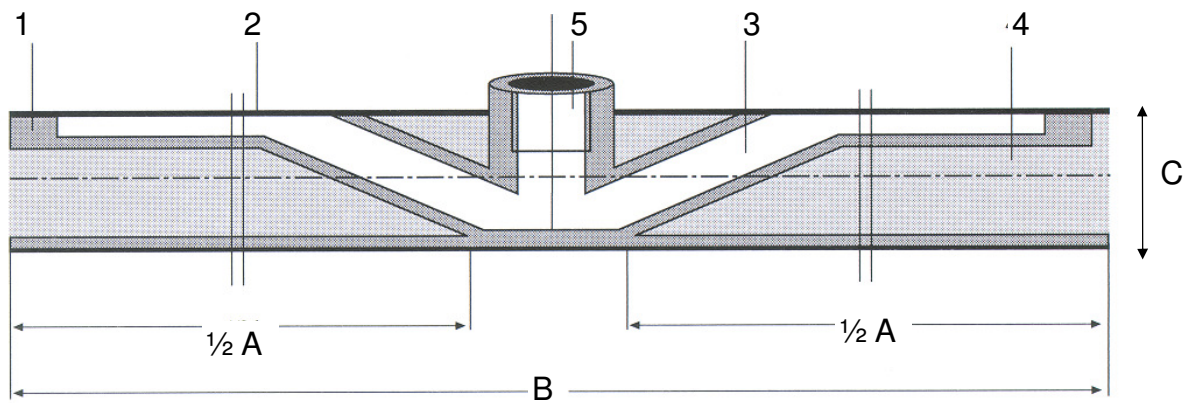

A effective membrane length	1000	1500	2000
B total diffuser length	1200	1700	2200
C outer diameter	Ø 67	Ø 67	Ø 67

Dimensions in mm
 Dimensions given are subject to normal fabrication tolerances

Technical data

membrane tube diffuser MAGNUM T[®]



04 2008

1. Storage

The membrane tube diffuser must be stored in their original packaging under adherence to DIN 7716 in a dry and ventilated room. Do not store in the open air!

2. Damage

Each individual diffuser, especially the membrane hose, must be checked for damage; the hose fastening clamps must be checked to ensure that these are seated properly.

3. Installation and test run

Prior to the installation of the membrane tube diffuser, impurities such as stones, pieces of wood, etc. must be cleaned from the pipelines and the reservoir.

The MAGNUM T[®] is installed as follows:

The MAGNUM T[®] is supplied with an insertion nut with a 1" connecting thread.

The connecting tube must be manually screwed in up to the insertion nut thread runout. When screwing in, ensure that tilting is out of the question, in order to avoid damaging the threads.

Immediately following the completion of installation, a test run must be carried out with clean water in the tank.

A test is carried out for leaks with a water level which is, at most, 20 cm above the membrane tube diffuser.

The membrane tube diffuser must blow once per week for approximately 10 minutes at medium air volume. No operations such as, e.g. painting, welding, concrete sealing, etc., which may cause damage, may be carried out in the vicinity of the membrane tube diffuser. In the event of operations on the reservoir, the membrane tube diffuser must be protected from falling parts.

If commissioning is not carried out immediately following the test run, the water coverage must be increased to 1 m. The water coverage must be guaranteed until commissioning is finally carried out; attention must be paid to water evaporation in this case.

In order to prevent membrane ageing as a result of environmental influences, a period of four weeks must not be exceeded between installation and the test run (water coverage). After the membrane tube diffuser have been heated via solar radiation, the tightening torque must be checked again.

4. Operation

Oil, dust and solvent-free air expulsion and filtration are prerequisites. Dust filters for environmental dust must be designed for a retention capacity of 81% according to BS 6540 (Ashrae 52-76). The air temperature at the inlet to the membrane tube diffuser must not exceed 80°C. Higher temperatures are only possible following consultation with the manufacturer. If the membrane tube diffuser are pressurised with a minimum air flow over a long period of time, a phase of approximately 20 minutes' duration at maximum air flow must be carried out 1x per week. The water temperature must lie between 5°C and 30°C. The air pressure must be limited to max. 10 Nm³ per hour and per metre of diffuser length.

5. Cleaning

After pumping the tank or basin out or pulling the diffuser-racks up, care must be taken to ensure that any deposits which may be present on the membranes do not dry on. The membranes can be cleaned with a high-pressure cleaner with a water temperature of 60°C. The function of the membranes is impeded as a result of dried-on deposits.